

SHATTERPRO™ PRE-TESTING

Remove insulator strip from between battery clip and battery.

Use the Sentrol 5709C hand-held tester to set the sensor into test mode. Set the tester to tempered glass, hold the tester speaker directly on top of the sensor and activate the tester. The sensor will alarm, then it will go into test mode for one minute. When in test mode the LED on the sensor will blink continuously. Extend the test mode time by firing the tester at the sensor at least once a minute.

Test the Sensor

1. Holding the tester near the surface of the glass, **aim the tester at the ShatterPro™** and hold down the test button. If drapes or blinds are present, test with the hand-held tester behind the closed drapes or blinds (do not use sensor with heavy or lined drapes). If the sensor is mounted on the same wall, point the tester at the opposite wall.
2. The 5709C tester has a different setting for each type of glass. The tester should always be set for tempered or laminated glass (either is correct and both have the same range) unless the installer is certain that all the glass to be protected is plate glass.

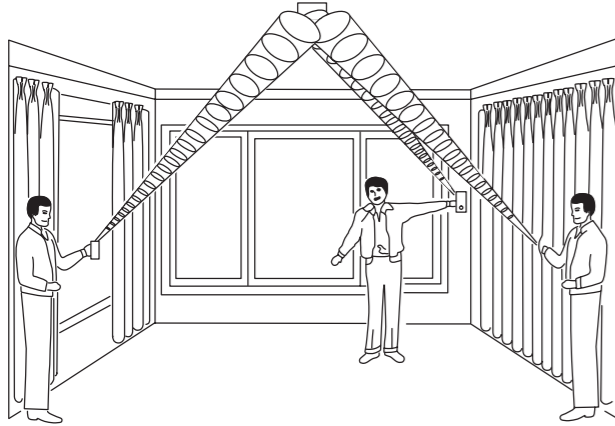

When the LED on the sensor goes solid momentarily while the tester is triggered, the glass is within detection range.

If the LED does not go solid, but simply continues blinking as before, reposition the sensor closer to the protected windows and retest. This may require adding additional sensors in order to achieve adequate coverage. It is very rare that the sensor will not activate within its stated range of coverage. Double-check adequate battery strength in the hand-held tester. A new tester battery will likely restore range.

The sensor will automatically change from test mode to normal mode approximately one minute after it last hears the hand-held tester.

IMPORTANT! Room acoustics can artificially extend the range of a glassbreak sensor. The specified range of the ShatterPro has been established for worst-case conditions. *While the sensor will likely function at additional range, it may miss a minimum output break or room acoustics may be changed at some future time, bringing sensor range back into normal 20' (6 m) conditions. Do not exceed the rated range of the sensor, regardless of what the tester shows.*

HOW THE TEST MODE WORKS

The Pattern Recognition Technology™ of the ShatterPro™ ignores most false alarm sounds, including glassbreak testers, in order to test the ShatterPro™, a test mode is used. With the sensor in test mode, processing of the glassbreak pattern in the upper and lower frequencies is disabled. The ShatterPro is then listening only for the mid-range frequencies, which the 5709C tester reproduces. It's the mid-range frequencies that determine sensor range.

IN NORMAL MODE THE LED DOES NOT BLINK UNLESS IT HEARS A LOUD SOUND. IN NORMAL MODE, THE SHATTERPRO WILL NOT TRIP TO THE TESTER, UNLESS THE TESTER IS HELD NEXT TO THE SENSOR.

NOTE: EACH TIME THE SENSOR ALARMS IT ALSO GOES INTO TEST MODE FOR ONE MINUTE.

HAND CLAP TEST

The ShatterPro 5845 can be checked by the installer or end user while in normal mode, simply by clapping hands loudly under the sensor. The LED will blink twice, but the sensor will not trip. This verifies visually that there is power to the sensor, and that the microphone and circuit board are functioning.

The hand clap activation is only momentary, so there is not appreciable effect on battery life.

To disable this custom test function, remove the circuit board from the housing and clip one of the wires on the LED. The LED will no longer be operational, but the sensor can still be tested using the transmitter and the control panel.

MOUNTING

1. Remove insulator strip from between battery clip and battery.
2. Program the transmitter into control unit using learn mode and by pressing the Test Button.
3. Mount the ShatterPro.
4. Secure transmitter to ShatterPro using double-stick tape provided. Orient as shown below.
5. Snap the ShatterPro cover in place.
6. Test with Sentrol 5709C Hand-held Tester as directed.

TO REMOVE SENSOR MODULE, DEPRESS LATCH, ROCK THE MODULE UP OFF THE POSTS

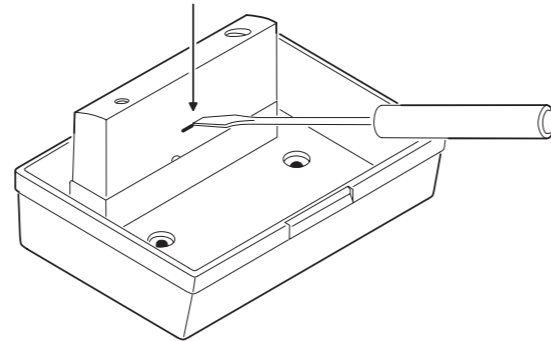

USE THE SCREWS AND ANCHORS PROVIDED TO MOUNT CASE TO THE WALL

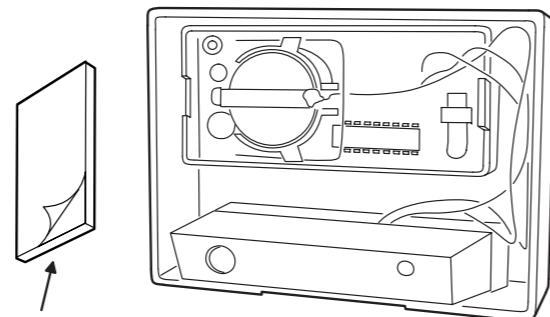
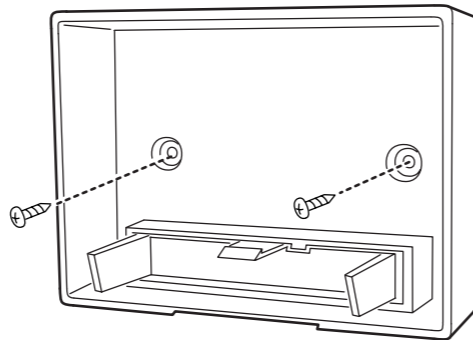

APPLY THE SUPPLIED DOUBLE STICK TAPE TO THE BACK OF THE TRANSMITTER AND SECURE IN CASE AS SHOWN

CHANGING THE BATTERY

6-Volt Model 584506-W

(shares transmitter battery)

Red — POSITIVE to battery + {Strap}

Black — NEGATIVE (COM.)

White — TRIGGER (EXT. CONT.) closes on alarm to battery (-)

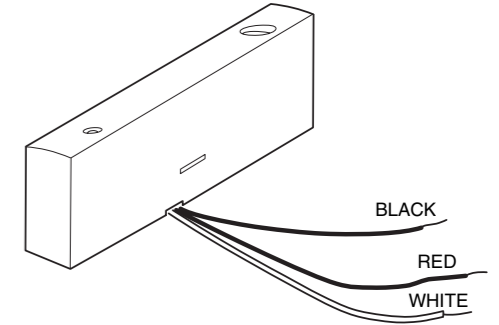

WHEN CONSOLE INDICATES A SENSOR LOW BATTERY, OPEN SENSOR CASE AND REPLACE BATTERIES

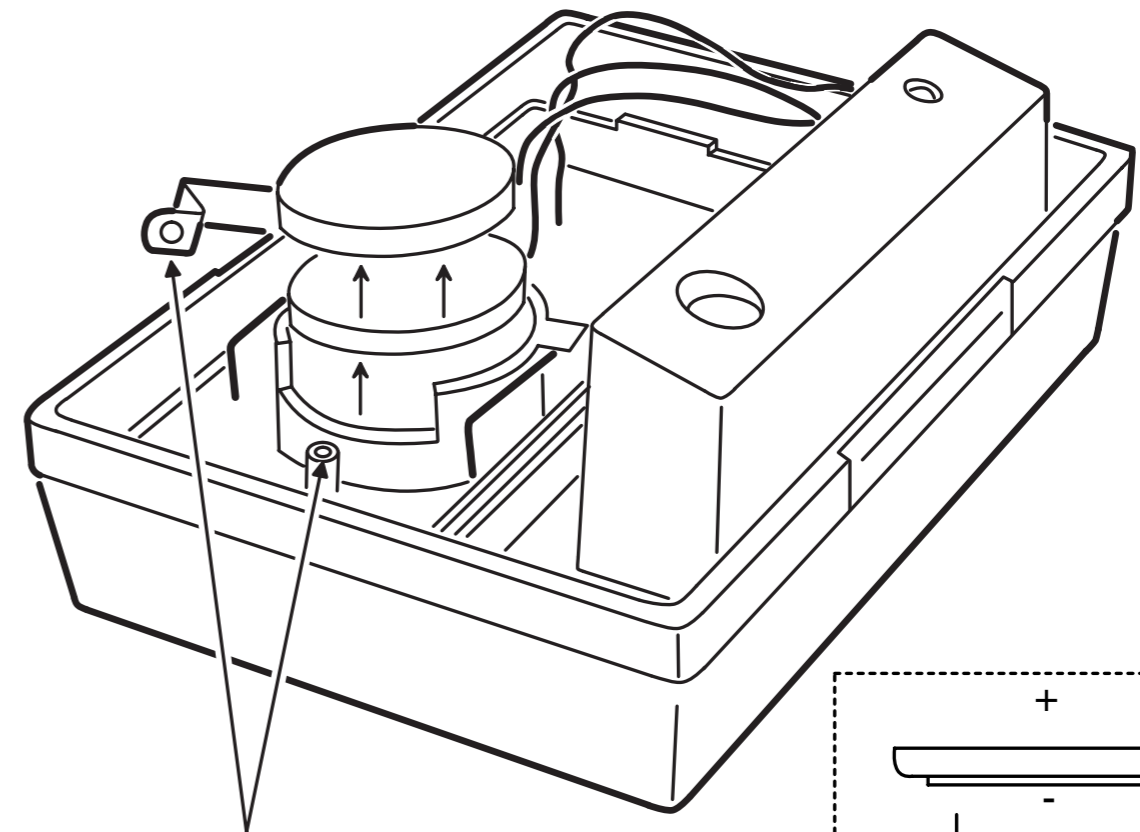

REMOVE BATTERY CLIP SCREW AND MOVE CLIP TO SIDE TO ACCESS BATTERIES

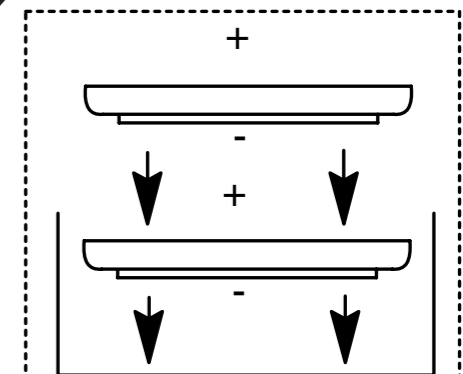

INSTALL TWO TYPE DL 2450 BATTERIES (+) SIDE UP

R&TTE VAAE 27839, EMC, SFT, ETS

Linear Corporation declares that the apparatus DXS-91/EC complies with the essential requirements and other relevant provisions of Directive 1995/5/EC.

SHATTERPRO™ SPECIFICATIONS

Power Requirements	Two type 2450 batteries
Operating	12 mA (MAX)
Standby	30 μ A (MAX)
RF Encoding	Linear DXS Format (AID PPM @ 200bps)
Number of Codes	1,048,575

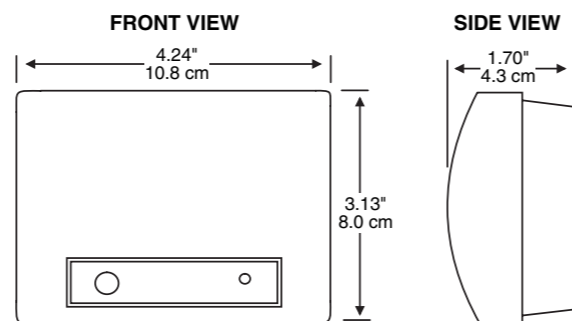

INSTALLATION TIPS

Temperature Range 32° to 122° F (0° to 50° C)
 Color White

1. The ShatterPro is designed to detect the shattering of framed glass mounted in an outside wall. "Testing" the sensor with unframed glass, broken bottles, etc. may not trip the sensor. The ShatterPro typically does not trip to glass break tests in the middle of a room as such breaks are false alarms.
2. False alarms are most likely to occur when installed on a 24-hour loop in glass airlocks and glass vestibule areas, when mounted above sinks, when used in residential car garages and in other small, acoustically live rooms and rooms where multiple sounds can reflect and eventually duplicate the glass break frequency pattern. For occupied area glass break protection in such applications, use Sentrol shock sensors.

DIMENSIONS

3. Installing the ShatterPro on 24-hour loops will increase false alarms. The ShatterPro is recommended for perimeter loops and is designed to function without false alarms in occupied areas. On a 24-hour loop, which is armed all day/all night every day, the false alarm technology will be pushed to its limit since some sounds in some conditions can duplicate the points on the glass break patten that the ShatterPro detects. Install the ShatterPro on a perimeter loop, which is armed whenever the door and window contact are armed. For occupied area installations, ShatterPro's false alarm immunity is best in rooms with only moderate noise.
4. ShatterPro detects the shattering of glass. Like all glassbreak sensors, it may not consistently detect cracks in glass or bullets which break through

INTERNATIONAL WARRANTY

This Linear product is warranted against defects in material and workmanship for twelve (12) months. The Warranty Expiration Date is labeled on the product. **This warranty extends only to wholesale customers** who buy direct from Linear or through Linear's normal distribution channels. **Linear does not warrant this product to consumers.** Consumers should inquire from their selling dealer as to the nature of the dealer's warranty, if any. **There are no obligations or liabilities on the part of Linear Corporation for consequential damages arising out of or in connection with use or performance of this product or other indirect damages with respect to loss of property, revenue, or profit, or cost of removal, installation, or reinstallation. All implied warranties, including implied warranties for merchantability and implied warranties for fitness, are valid only until Warranty Expiration Date as labeled on the product. This Linear Corporation Warranty is in lieu of all other warranties express or implied. For warranty service on Linear equipment return product, at sender's expense to:**
 Linear Hong Kong 19/F Hounor Industrial Centre, 6 Sun Yip StreetChai Wan, Hong Kong Attention: Repairs Department

REPAIRS POLICY

Charges will be made for equipment that is not in warranty, shows customer abuse, or is damaged by the effects of lightning, water, fire, or other abnormal happenings. Customer's equipment sent in for repair may be repaired or replaced with new or remanufactured equipment at Linear's discretion.

The customer is always responsible for shipping and handling charges to the repairs facility. Linear will pay return shipping and handling charges on "in warranty" products shipped back to the customer. The customer will be billed for the return shipping and handling charges on "out of warranty" products. There will be a 50% expedite fee for any express requests. The International Sales Manager must be notified prior to the return of product to Linear. All international returns must have an International Repair Authorization number (IRA#). The number must be marked on all packages. Failure to do so will cause delays in processing.

IMPORTANT !!!

Linear radio controls provide a reliable communications link and fill an important need in portable wireless signaling. However, there are some limitations which must be observed. The radios are required to comply with local rules and regulations as radio devices. As such, they have limited transmitter power and therefore limited range. A receiver cannot respond to more than one transmitted signal at a time and may be blocked by radio signals that occur on or near their operating frequencies regardless of code settings. Changes or modifications to the device may void regulatory compliance. Infrequently used radio links should be tested regularly to protect against undetected interference or fault. A general knowledge of radio and its vagaries should be gained prior to acting as a wholesale distributor or dealer, and these facts should be communicated to the ultimate users.

NOTE:

This equipment has been tested and found to comply with the limits for a Class B digital device pursuant to Part 15 of the FCC Rules. These limits are designed to provide reasonable protection against harmful interference in a residential installation. This equipment generates, uses and can radiate radio frequency energy and, if not installed and used in accordance with the instructions, may cause harmful interference to radio communications. However, there is no guarantee that interference will not occur in a particular installation. If this equipment does cause harmful interference to radio or television reception, which can be determined by turning the equipment off and on, the user is encouraged to try to correct the interference by one or more of the following measures.

- Re-orient or relocate the receiving antenna.
- Increase the separation between the equipment and receiver.
- Connect the equipment into an outlet on a circuit different from that to which the receiver is connected.
- Consult the dealer or an experienced radio/TV technician for help.

This device complies with Part 15 of the FCC Rules. Operation is subject to the following two conditions: (1) This device may not cause harmful interference, and (2) this device must accept any interference received, including interference that may cause undesired operation.

Wireless ShatterPro™

Advanced Acoustic Sensor With Pattern Recognition Technology™

Protected under U.S. Patent 5,192,931 and other patents pending

Linear

Installation Instructions

Model DXS-91/EC Product # SSA00017

the glass or break out the glass. Glass break sensors should always be backed up by interior protection.

The DXS-91/EC is a glass break detector with a built-in transmitter designed for use with Linear's DXS and DX Format receivers. When breaking glass is detected, the transmitter sends a digitally coded signal to its companion receiver/control.

The digital DX code format features more than one million possible codes. Each transmitter is precoded at the factory to a unique code so no field coding is required. The DXS-91/EC can send three different signals: alarm, low battery and status.

The unit is powered by two 3-volt lithium batteries. These batteries will last for approximately two and one half years under normal climatic conditions. If the battery voltage drops below a preset level, a low battery signal is sent with every alarm or test transmission.

NOTE TO THE INSTALLER: Regular maintenance by the installer and frequent user testing are vital for proper system operation. Refer to the figure under "MOUNTING" for test button locations. **THE TRANSMITTER SHOULD BE TESTED AT LEAST ONCE A MONTH.**

The installer should assume responsibility for developing and offering a regular maintenance program to the user as well as acquainting the user with the proper operation and limitations of the alarm system and its component parts. Recommendations must be included for a specific program of frequent testing to ensure the system's proper operation at all times.

As with all glassbreak sensors, detection is reduced with same-wall mounting, since such detection is partially dependent on glass break sound reflecting off the opposite wall. Test range with Sentrol's 5709C tester held flat against the glass. Depending on room acoustics, there may be a reduction in range.

Since the sound of breaking glass travels directionally out from the broken window, the best location for mounting the sensor is on the opposite wall, assuming that wall is within the sensor's range. For this same reason, a ceiling mounted sensor will have better detection located 6-10' (2-3 m) back from the glass rather than directly above the glass.

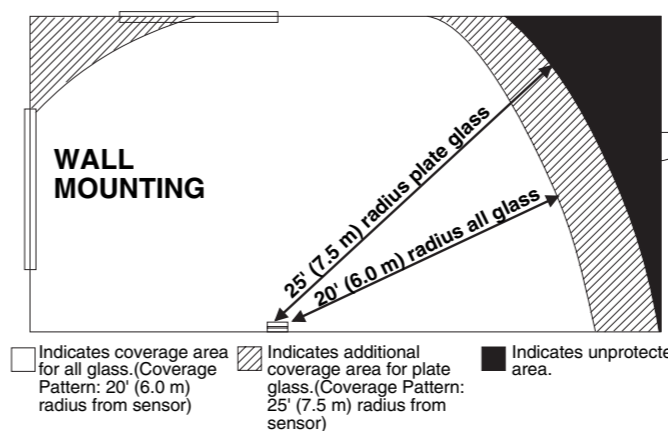

USE A SHATTERPRO™ FOR:

- Perimeter loops for occupied or unoccupied buildings.
- Rooms with blinds and unlined drapes.
- Recommended glass size of 1' x 2' (0.3 m x 0.6 m) or larger.
- Minimum glass size of 1' x 1' (0.3 m x 0.3 m).
- Glass thicknesses as follows:

Plate Glass:	3/32" to 1/4" (2.4 mm to 6.4 mm)
Tempered Glass:	1/8" to 1/4" (3.2 mm to 6.4 mm)
Wired Glass:	1/4" (6.4 mm)
Laminated Glass	1/8" to 1/4" (3.2 mm to 6.4 mm)

FOR BEST DETECTION, AVOID INSTALLING IN:

- Rooms with lined, insulating or sound deadening drapes.
- Rooms with closed wooden window shutters inside.
- Ceilings higher than 15' (4.5 m), if mounting on ceiling.

SHATTERPRO™ RANGE OF COVERAGE

The coverage range is for worst-case breaks in worst-case applications. ShatterPro™ range of coverage is measured in radius distance from the sensor.

- 25' (7.6 m) radius of coverage for plate glass.
- 20' (6 m) radius of coverage for tempered, wired, laminated glass.
- Use 20' (6 m) radius if unsure of glass type.
- Sensor radius range of 20' (6 m) to the wall is the same as 25' (7.6 m) or greater when measuring on the angle from the sensor to the bottom of the glass.
- If not using hand-held tester to verify range, reduce range to 15' (4.5 m) for windows with blinds and unlined drapes.
- Reduce coverage 50% for armor-coated glass.
- No sensitivity adjustment.

FOR FALSE ALARM IMMUNITY, AVOID INSTALLING IN:

- 24-hour loop applications (perimeter loop OK).
- Where white noise such as air compressor noise is present. (May cause false alarms by saturating the glass break frequency spectrum.)
- Rooms smaller than 10' x 10' (3 m x 3 m) and rooms with multiple sounds such as small kitchens, glass booths, noisy areas, garages, etc.

SHATTERPRO™ MOUNTING LOCATION

For best false alarm immunity the sensor should be located at least 4' (1.2 m) away from noise sources (televisions, speakers, sinks, doors, etc.). The sensor must always be in direct line of sight of all windows to be protected. It cannot consistently detect glass breaking around corners, in other rooms, etc. There is no front or back, up or down, orientation of the sensor required.

Wall Mounting

Mount the ShatterPro™ on an adjoining or opposite wall from the windows to be protected. For best detection, sensors should not be mounted on the same wall as a window to be protected.

Ceiling Mounting

Mount the sensor on any type of ceiling in direct line of sight of the windows to be protected, at least 1' (0.3 m) and preferably 3' (1 m) back from the glass.

