

DXR-702/EC

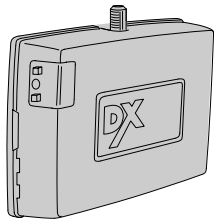

TWO-CHANNEL DIGITAL RECEIVER

Installation Instructions



Linear

(760) 438-7000 • FAX (760) 438-7043
www.linearcorp.com

PRODUCT DESCRIPTION

The DXR-702/EC is a two-channel digital receiver with two isolated relay outputs designed for use with Linear's DX Format transmitters. This receiver can be used in a variety of remote control applications. When the receiver detects a signal from a transmitter programmed into its memory, the appropriate relay output activates. The relays have four optional output configurations. When the relays are set to latch, the receiver outputs will follow the open/close door status sent from DXT-31/EC door/window transmitters.

In a typical installation, the receiver is connected to an alarm control panel, door strike, camera, high current relay or some other devices. Transmitters are used to activate or control the devices. The receiver should be mounted with the supplied mounting bracket indoors or inside a weather resistant *non-metallic* housing. The digital DX code format features over a million possible codes, so no field coding is required. For versatility, *any transmitter can be programmed into any receiver channel*. Receivers must be programmed to the transmitter's code before system testing and operation. Up to 32 transmitters maximum can be programmed into the receiver. The transmitters can be split in any number between the two receiver channels.

Receiver channel two is a special channel. If channel two memory is empty, with no transmitters programmed into it, it will report low battery signals from any channel one transmitters capable of

sending them. When a low battery transmission is received, the channel two relay will latch, regardless of how the option jumpers are set. The relay will remain engaged until the channel two program button is pressed. The low transmitter batteries should be replaced before resetting the relay.

The unit can be powered from a 11-17 VDC or 12-16 VAC power source. The relays' normally open and normally closed contacts can switch up to 1 amp at 24 volts AC/DC.

Cutting jumpers select how the relays activate. Four settings are possible. Both relays will function with the same option. The factory setting causes the relays to engage for four seconds each activation. Optionally, the relays can be set to engage for one second, toggle on with one activation then off with the next, or latch engaged for door status or until reset by pressing the program button. A 15 cm wire whip antenna screws into the receiver's antenna connector. Optionally, a remote antenna (Linear EXA-1000/EC or EXA-2000/EC) can be connected to the receiver for greater radio range. The red program indicator lights during RF reception. The installer can verify that signals are being sent from transmitters and diagnose interference problems by viewing the indicator. The indicator also lights during memory programming/erasing and flashes to count the number of transmitters in memory.

DXR-702 FEATURES

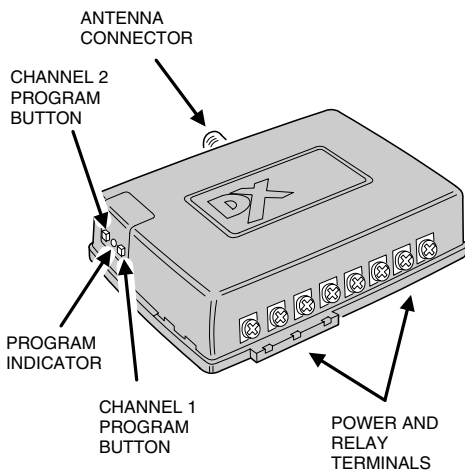

TERMINAL DETAILS

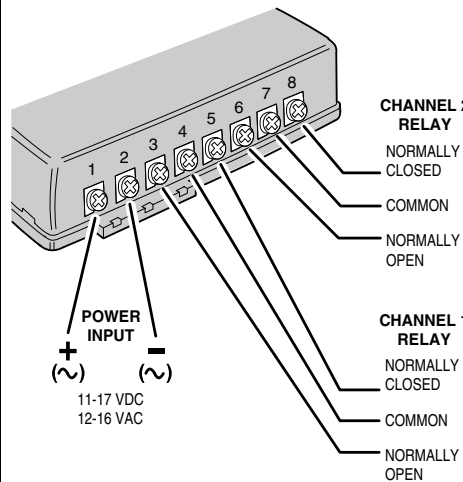

CUTTING RELAY OPTION JUMPERS

RELAY OPTIONS EFFECT BOTH RELAYS

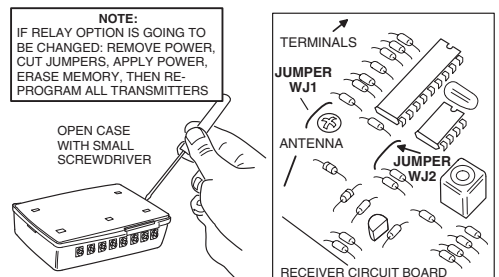

RELAY OPTION	JUMPER WJ1	JUMPER WJ2
4 SECOND LATCH	SOLID	SOLID
1 SECOND LATCH	CUT	SOLID
LATCH UNTIL RESET ++	SOLID	CUT
TOGGLE ON AND OFF ++	CUT	CUT

BE SURE POWER IS OFF WHEN CUTTING JUMPERS

++ CAN BE RESET BY PUSHING THE PROGRAM BUTTON ONCE

NOTE:
TO MONITOR DOOR OPEN/CLOSE STATUS WITH DXT-31/EC TRANSMITTERS, SET RELAYS TO LATCH.
RELAY ON = DOOR OPEN - RELAY OFF = DOOR CLOSED
OTHER TYPES OF TRANSMITTERS WILL LATCH RELAYS ON UNTIL RESET

INSTALLATION TIPS

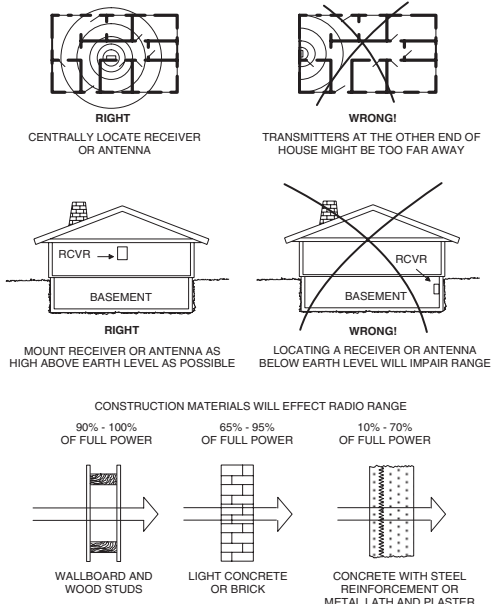

MOUNTING RECEIVER

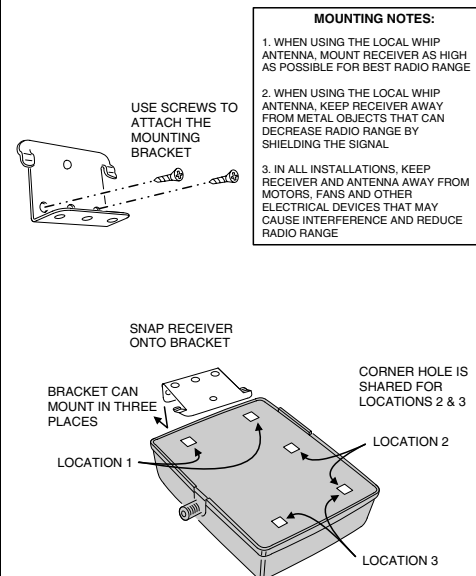

ANTENNA INSTALLATION

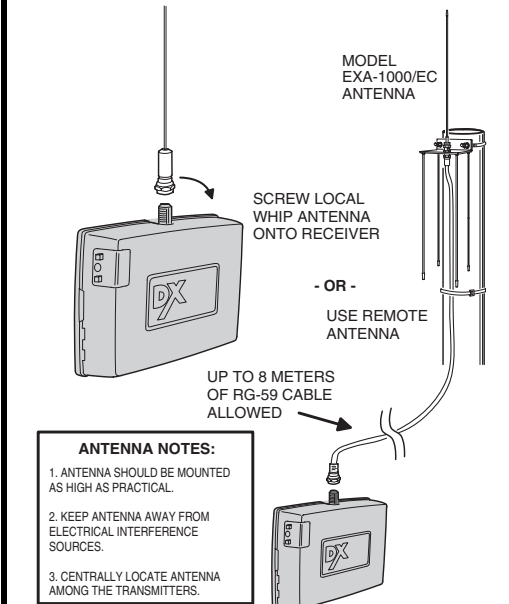

TERMINAL CONNECTIONS

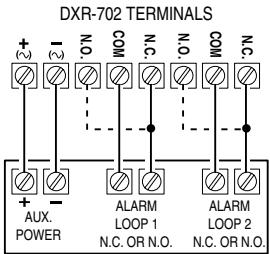

NOTE:
LATCHING MODE
ALLOWS PANEL
TO SHOW DXT-31
DOOR STATUS

**ALARM PANEL CONNECTION WITH DOOR STATUS
LATCHING RELAY OPTION**

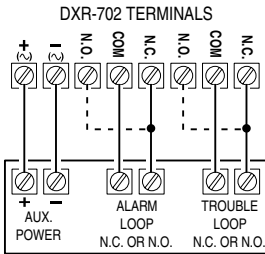

NOTE:
CHANNEL 2 MUST
BE EMPTY TO
REPORT LOW
BATTERY

**ALARM PANEL CONNECTION WITH LOW BATTERY REPORTING
LATCHING RELAY OPTION**

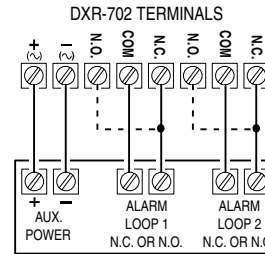

NOTE:
TRANSMITTERS
WILL AUTO
RESTORE AFTER
1 SECOND

**ALARM PANEL CONNECTION FOR PANIC BUTTONS
1 SECOND RELAY OPTION**

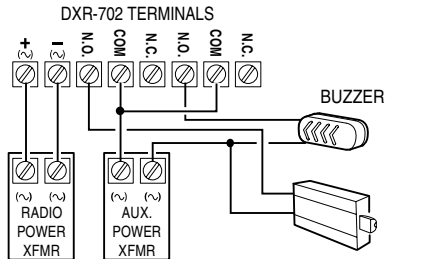

**ACCESS CONTROL CONNECTION
4 SECOND RELAY OPTION**

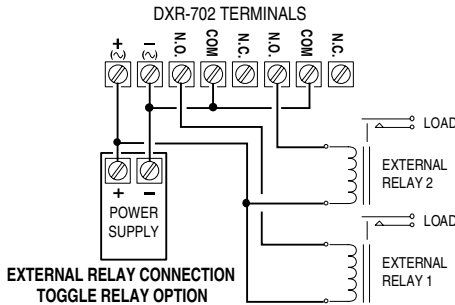

**EXTERNAL RELAY CONNECTION
TOGGLE RELAY OPTION**

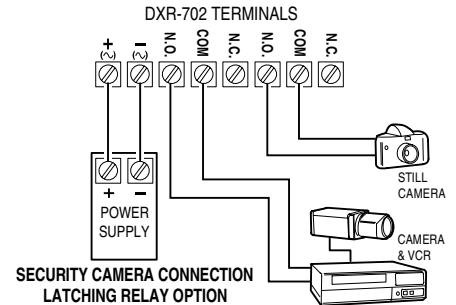

**SECURITY CAMERA CONNECTION
LATCHING RELAY OPTION**

BUTTON AND INDICATOR FUNCTIONS

FUNCTION	PROGRAM BUTTONS	PROGRAM INDICATOR
NORMAL OPERATION	RELEASES LATCHED RELAY FOR CHANNEL 1 OR 2	LIGHTS WHEN TRANSMITTER IS RECEIVED, FLASHES WHEN INTERFERENCE IS RECEIVED
PROGRAMMING MEMORY	PRESS AND RELEASE FOR CHANNEL 1 OR 2	LIGHTS FOR 3 SECONDS FOR PROGRAMMING
CHECKING MEMORY	PRESS FOR CHANNEL 1 OR 2 UNTIL BLINK AND RELEASE	BLINKS THE NUMBER OF TRANSMITTERS IN CHANNEL MEMORY
ERASING MEMORY	FOR CHANNEL 1 OR 2, PRESS AND HOLD THROUGH THE COUNT THEN HOLD FOR 5 SECONDS MORE	AFTER BLINKING COUNT, A PAUSE THEN A SINGLE BLINK AS MEMORY IS ERASED (DOUBLE BLINK ON CHANNEL 2)

PROGRAMMING MEMORY

- PRESS AND RELEASE PROGRAM BUTTON FOR THE DESIRED CHANNEL.
- PROGRAM INDICATOR WILL LIGHT FOR 3 SECONDS IF THERE IS ROOM IN THAT CHANNEL'S MEMORY FOR ANOTHER TRANSMITTER (32 TRANSMITTERS MAXIMUM TOTAL ALLOWED BETWEEN BOTH CHANNELS IN THE RECEIVER).
- WITHIN 3 SECONDS, SEND SIGNAL FROM TRANSMITTER, PROGRAM INDICATOR WILL FLICKER AS SIGNAL IS RECEIVED.
- REPEAT THE ABOVE THREE STEPS FOR EACH ADDITIONAL TRANSMITTER.

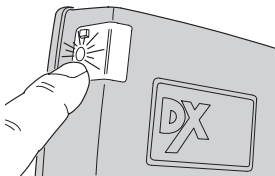

AFTER PUSHING THE RECEIVER'S PROGRAMMING BUTTON, YOU ONLY HAVE 3 SECONDS TO SEND A SIGNAL BEFORE PROGRAMMING MODE STOPS

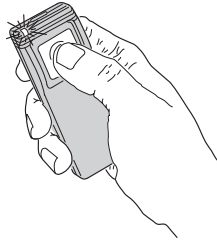

MULTI-CHANNEL TRANSMITTER NOTE:
EACH RECEIVER CHANNEL CAN ONLY BE PROGRAMMED TO ACTIVATE FROM A SINGLE BUTTON ON A MULTI-CHANNEL TRANSMITTER. LEARNING THE SAME BUTTON INTO BOTH CHANNELS ACTIVATES CHANNEL ONE ONLY.

CHECKING MEMORY

- PRESS PROGRAM BUTTON FOR THE DESIRED CHANNEL AND HOLD FOR ABOUT TWO SECONDS UNTIL INDICATOR LIGHTS THEN RELEASE.
- COUNT THE NUMBER OF INDICATOR BLINKS, THIS IS THE TOTAL NUMBER OF TRANSMITTERS PROGRAMMED INTO THAT CHANNEL.

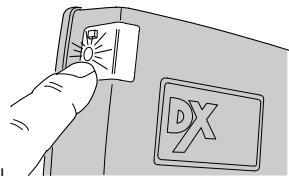

PUSH UNTIL INDICATOR LIGHTS

NOTE: DO NOT CONTINUE TO PRESS BUTTON OR MEMORY WILL BE ERASED

SYSTEM TESTING

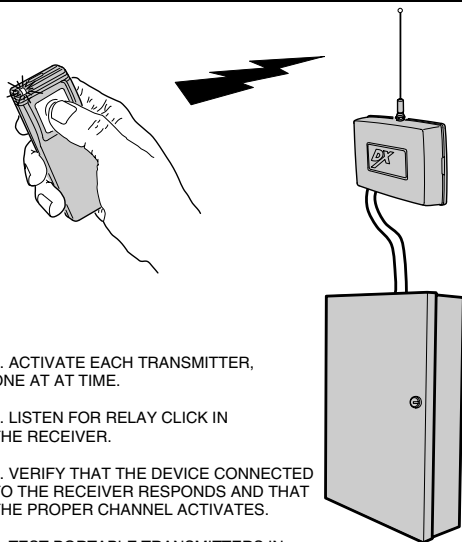

- ACTIVATE EACH TRANSMITTER, ONE AT A TIME.
- LISTEN FOR RELAY CLICK IN THE RECEIVER.
- VERIFY THAT THE DEVICE CONNECTED TO THE RECEIVER RESPONDS AND THAT THE PROPER CHANNEL ACTIVATES.
- TEST PORTABLE TRANSMITTERS IN VARIOUS LOCATIONS TO DETERMINE SYSTEM PERFORMANCE.

ERASING MEMORY

- PRESS PROGRAM BUTTON FOR THE CHANNEL TO ERASE AND CONTINUE TO HOLD IT THROUGH THE COUNT OF THE TRANSMITTERS.
- CONTINUE TO HOLD THE BUTTON AFTER THE COUNT UNTIL THE INDICATOR BLINKS ONCE FOR CHANNEL ONE, TWICE FOR CHANNEL TWO (ABOUT FIVE SECONDS AFTER THE COUNT).
- ALL TRANSMITTERS PROGRAMMED INTO THAT CHANNEL WILL BE ERASED.

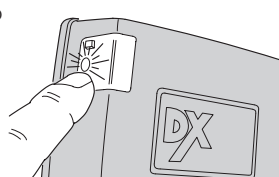

PUSH AND HOLD BUTTON FOR FIVE SECONDS AFTER THE TRANSMITTER COUNT

R&TTE VAAE 27840, EMC, SFT, ETS

Linear Corporation declares that the apparatus DXR-702/EC complies with the essential requirements and other relevant provisions of Directive 1995/5/EC.

INTERNATIONAL WARRANTY

This Linear product is warranted against defects in material and workmanship for twelve (12) months. The Warranty Expiration Date is labeled on the product. **This warranty extends only to wholesale customers** who buy direct from Linear or through Linear's normal distribution channels. **Linear does not warrant this product to consumers.** Consumers should inquire from their selling dealer as to the nature of the dealer's warranty, if any. **There are no obligations or liabilities on the part of Linear Corporation for consequential damages arising out of or in connection with use or performance of this product or other indirect damages with respect to loss of property, revenue, or profit, or cost of removal, installation, or reinstallation.** All implied warranties, including implied warranties for merchantability and implied warranties for fitness, are valid only until Warranty Expiration Date as labeled on the product. This Linear Corporation Warranty is in lieu of all other warranties express or implied. For warranty service on Linear equipment return product, at sender's expense to:

Linear Hong Kong 19/F Hounor Industrial Centre, 6 Sun Yip Street/Chai Wan, Hong Kong
Attention: Repairs Department

REPAIRS POLICY

Charges will be made for equipment that is not in warranty, shows customer abuse, or is damaged by the effects of lightning, water, fire, or other abnormal happenings. Customer's equipment sent in for repair may be repaired or replaced with new or remanufactured equipment at Linear's discretion.

The customer is always responsible for shipping and handling charges to the repairs facility. Linear will pay return shipping and handling charges on "in warranty" products shipped back to the customer. The customer will be billed for the return shipping and handling charges on "out of warranty" products.

There will be a 50% expedite fee for any express requests. The International Sales Manager must be notified prior to the return of product to Linear. All international returns must have an International Repair Authorization number (IRA#). The number must be marked on all packages. Failure to do so will cause delays in processing.

IMPORTANT !!!

Linear radio controls provide a reliable communications link and fill an important need in portable wireless signaling. However, there are some limitations which must be observed. The radios are required to comply with local rules and regulations as radio devices. As such, they have limited transmitter power and therefore limited range.

A receiver cannot respond to more than one transmitted signal at a time and may be blocked by radio signals that occur on or near their operating frequencies, regardless of code settings. Changes or modifications to the device may void regulatory compliance. Infrequently used radio links should be tested regularly to protect against undetected interference or fault. A general knowledge of radio and its vagaries should be gained prior to acting as a wholesale distributor or dealer, and these facts should be communicated to the ultimate users.